



Portunus v3.1

Motor Design Ltd is pleased to announce the release of this new version of PORTUNUS the software solution for multi domain system level simulation created by Cedrat Group and Adapted Solutions. By enabling the import of models in the VHDL-AMS standard as well as a brand new Power Electronics Library, PORTUNUS Version 3.1 goes one step ahead in the world of system simulation.

PORTUNUS is a system simulator whose applications range from the simulation of drive systems and switched mode power supplies to investigation of the heating of electronic components. It is a coupled system simulator which allows both analogue and digital components within a most user-friendly interface. System modelling can include combinations of electrical networks, thermal networks, block diagrams and state machines; all cleanly modelled in cascading sub-sheets. PORTUNUS comes with a series of analysis types, namely transient, AC, DC and operation point computation, which can be launched, directly or through parametric or worst-case studies to better fit experimental need.

Extensive Libraries

The Thermal Library

PORTUNUS offers an extensive set of component libraries to meet the requirements of complex mixed system analysis. The Thermal Library was jointly developed by Adapted Solutions and Motor Design Ltd. The Thermal Library has a comprehensive set of components that make thermal analysis easy to perform. The user creates a thermal circuit using conduction, convection and radiation resistances, power and temperature sources, interface gaps and thermal capacitances. Setting up the circuit components is easily accomplished using the powerful dialogues – so called ‘wizards’. These are used to set geometry and material data from which the correct heat transfer formulation for each component is automatically selected. For instance, if the device being modelled includes a finned heat sink, then a convection resistance having U-shaped channels would be selected. The channel number, fin thickness, spacing and height, together with the selection of natural or forced convection and orientation, would be set in the wizard. The calculation of convection from the finned surface is automatically taken care of in the software. The user effort can be concentrated on putting all the geometric features into the circuit that are included in the device being modelled. The models can be used for steady state and transient calculations. Temperatures and power losses can be defined freely by means of constants, time functions and expressions. Thanks to the versatile data transfer possibilities provided by PORTUNUS coupling with other physical domains is simple. The losses that heat up a thermal network can be calculated from the values of current and voltage or speed and torque respectively. Similarly the calculated temperatures can be used to modify resistance values or other properties of electrical or mechanical components. The Thermal Library simplifies thermal analysis allowing the heat transfer specialist and non-specialist alike to quickly create accurate thermal models.

The Power Electronics Library

The new Power Electronics Library provides a comprehensive enhancement to PORTUNUS. The library contains more than 80 models for the simulation of power electronic systems, considering

all kinds of power conversion (AC/DC ... DC/AC). Beside predefined network models for typical topologies, a high value is set on providing models for control algorithms as modelling of these usually requires considerable effort. The Power Electronics Library has a modular structure. Models for the generation of control signals and the corresponding network models may be combined in the schematic or so called “units” comprising both parts can be used. Alternatively, the control algorithm models may work with user-defined networks, e.g. in order to use semiconductor models provided by the manufacturers. This flexible approach allows for the integration of higher-level control components to generator reference and release signals. Frequently used algorithms like Park/Clarke transformations, v-f control and sine wave sources of variable frequency and magnitude, complete the model set. In addition, model-specific dialogues or “wizards” and the comfortable PORTUNUS user interface simplify the creation of simulation models. The switch models used in the networks, the solver employed by PORTUNUS as well as efficient code of the control models and functional blocks, allow for short simulation time without neglecting accuracy. Quick overview of simulation results is guaranteed by the PORTUNUS output devices with numerical and graphical display and integrated post-processing providing signal and FFT characteristics.

PORTUNUS has the flexibility to incorporate user-defined components into the system. These components can be created using C++ programs, sub-sheets, non-linear look-up tables, or direct imports of SPICE or VHDL-AMS models. With VHDL-AMS a model description language exists, standardized by the IEEE that is suitable for describing and simulating analogue, digital and mixed-signal systems. A significant advantage of VHDL-AMS lays in the fact that both control algorithm and the system to be controlled, can be described in a convenient way. The considered systems may belong to different physical domains such as electrical, mechanical, thermal, hydraulic etc.

Motor Design Ltd is a market leader in the development and marketing of software for the design of electric motors. It also provides motor design consulting and training. It is a supplier of software to the industrial, automotive and aerospace industries with customers throughout the world.

To contact Motor Design Ltd please telephone +44 (0)1691 623305, email info@motor-design.com or take a look at the web site www.motor-design.com

Induction Motor Drive Using Three-Level Inverter

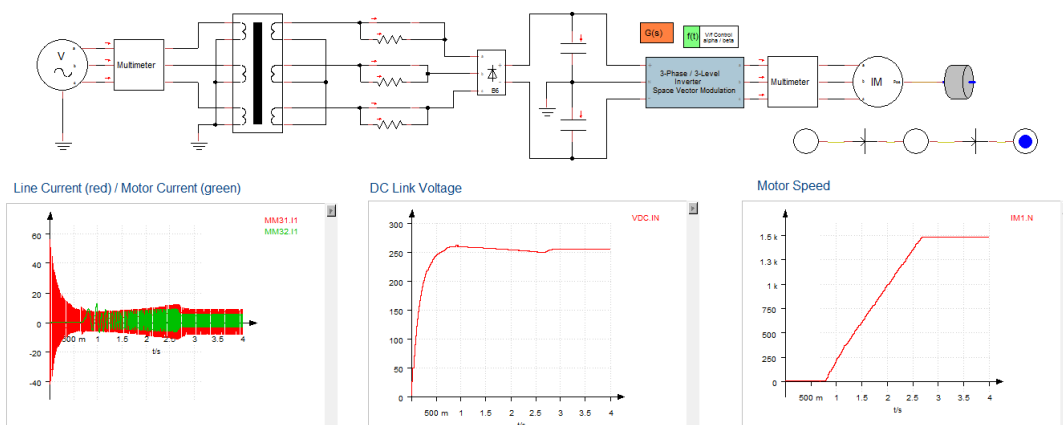

Sequence:

- 0 ... 0.6 s: Charging up DC Link
- 0.6 ... 2.6 s: Speeding up the Motor (constant v/f ratio)
- > 2.6 s: Steady-State Motor Operation

Parameters

- | | |
|------------|--|
| VDCmin=250 | Minimum DC Link Voltage [V] |
| from=50 | Nominal Output Frequency [Hz] |
| TS=500u | Sample Time of Space Vector Modulation [s] |
| Rcharge=5 | Charge Resistance [Ohm] |
| tramp=2 | Ramping Time [s] |

